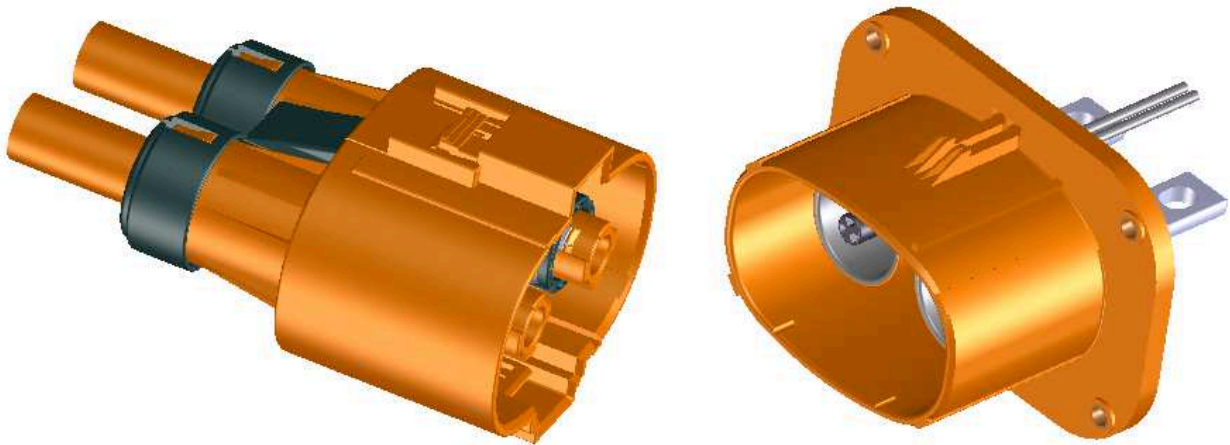

Imperium TM High Voltage High Current (HVHC) Connector System

SERIES:

171467-**** Bulkhead Mount Header Assembly

171466-9*** Cable Harness Component Kit

**DANGER OF SEVERE INJURY OR DEATH – HIGH VOLTAGE**

REVISION: B	ECR/ECN INFORMATION: EC No: UCP2014-4994 DATE: 2013/09/23	TITLE: PRODUCT SPECIFICATION FOR IMPERIUM 2 CIRCUIT CONNECTOR HARNESS TO DEVICE	SHEET No. 1 of 15
DOCUMENT NUMBER: PS-171467-001	CREATED / REVISED BY: J.Quiles	CHECKED BY: M.Data	APPROVED BY: A. Patel

- This connector is intended for use in high-voltage or high current applications.
- Proper use and care of this product is required to ensure it functions properly; misuse of this product may cause severe injury and/or death.
- If this connector has been modified, damaged, contaminated, or otherwise compromised, please discontinue using it immediately.
- DO NOT connect or disconnect this product while under load.

Use of this product requires that appropriate high voltage warning labels be applied to the cable assembly and/or in close proximity of the mated connector application in a manner that provides suitable warning to the end user and meets applicable laws. It is the responsibility of the OEM or manufacturer of the product in which this connector system is used to apply the appropriate high voltage warning label(s) to the final product. To the extent Molex is not responsible for the final cable assembly, MOLEX DISCLAIMS ALL WARRANTIES AND LIABILITY THAT RESULT FROM A FAILURE TO PROVIDE AN APPROPRIATE WARNING.

REVISION: B	ECR/ECN INFORMATION: EC No: UCP2014-4994 DATE: 2013/09/23	TITLE: PRODUCT SPECIFICATION FOR IMPERIUM 2 CIRCUIT CONNECTOR HARNESS TO DEVICE	SHEET No. 2 of 15
DOCUMENT NUMBER: PS-171467-001	CREATED / REVISED BY: J.Quiles	CHECKED BY: M.Data	APPROVED BY: A. Patel

1.0 SCOPE:

This Product Specification covers the 2 circuit, 32mm pitch Imperium™ HVHC Connector System using 1/0 (50mm²) cable size.

2.0 PRODUCT DESCRIPTION:

The IMPERIUM Connector series is a two circuit harness to device system with integrated circuits for power, signal and shielding. The power circuit terminals are terminated to a 1/0 shielded wire using crimp termination technology and a silver plating interface with a terminal tarnish protection lubricant. The shielding is part of the power cable and travels thru the connector and terminates to the panel. The signal is an HVIL (High Voltage Interlock) circuit and is a signal path to disable power when the harness is disengaged from the header.

2.1 DIMENSIONS:

2.1.1 Overall envelop when mated shown below. For header and harness sizes see their respective sales drawings.

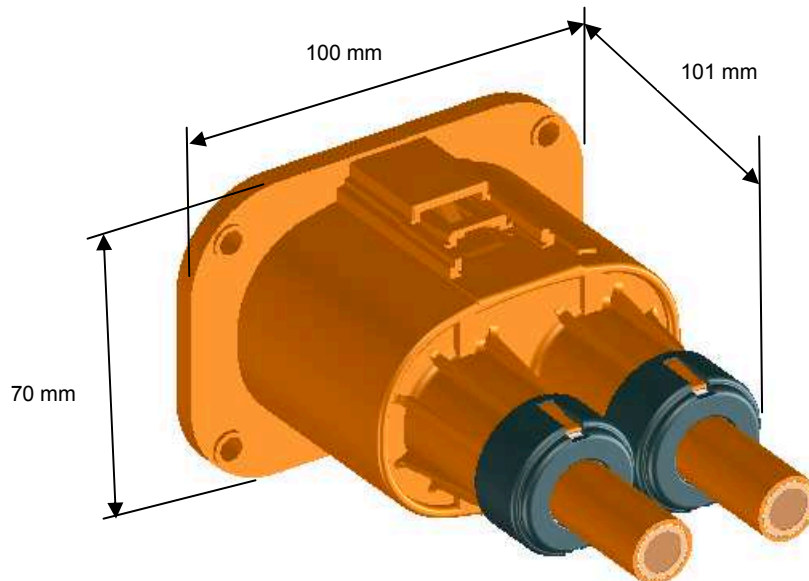

2.2 MATERIALS:

2.2.1 Housings: PBT, the main housing of each connector half (header and harness) is orange per industry recognition requirements. Remaining components are black PBT

2.2.2 Power terminals: Copper base material with silver over nickel plating, lubricant is used to inhibit tarnishing of the silver plate

REVISION: B	ECR/ECN INFORMATION: EC No: UCP2014-4994 DATE: 2013/09/23	TITLE: PRODUCT SPECIFICATION FOR IMPERIUM 2 CIRCUIT CONNECTOR HARNESS TO DEVICE	SHEET No. 3 of 15
DOCUMENT NUMBER: PS-171467-001	CREATED / REVISED BY: J.Quiles	CHECKED BY: M.Data	APPROVED BY: A. Patel

2.2.3 Power cable: Product tested with Champlain Cable part number EXTRAD-FSX1/0 (1/0 Cable is 1007 strands of copper wire with EMI braid)

Product can be used with equivalent wire (OD, stranding, voltage rating...per Application Specification)

2.2.4 Signal wire is TXL automotive grade 18 awg wire

2.2.5 Seals are silicon based resin

3.0 DOCUMENTS AND SPECIFICATIONS:

3.1 Harness Sales Drawing ****

3.2 Header Sales Drawing SD-171467-1000

3.3 Receptacle Harness Kit Sales Drawing SD-171466-9000

3.4 Application Specification AS-171467-001

4.0 RATINGS:

4.1 VOLTAGE

1000 Volts AC (RMS) per the cable listed in section 2.2.3

For creepage and clearance distance is referenced in AS-171467-001 see wire termination Section 9.3 and 9.4

CONNECTOR VOLTAGE RATING PER UL-1977

Alternate voltage rating allowed by UL: Exception taken for spacing less than those specified Are permitted if the device complies with the Dielectric Voltage-Withstand Test, section 17.3b

Applied voltage 1,000 volts plus twice the rated voltage per test method 17.4

4.2 CURRENT ON APPLICABLE WIRES

AWG	Amps	Nominal outside Insulation Diameter
1/0	250*	15.19 mm (.598 inch)

**Current rating is application dependent. The ratings listed in the chart are per EIA364-70 and should be used as a guideline only. Appropriate de-rating is required per ambient conditions, bussbar size, gross heating from adjacent modules or components, and other factors that influence connector performance. Wire type and stranding, tin coated or bare copper, wire length & crimp quality are other factors that influence current rating*

NOTE: Allowable 325 amp surge/peak current – 1 minute of every 8 hours.

REVISION: B	ECR/ECN INFORMATION: EC No: UCP2014-4994 DATE: 2013/09/23	TITLE: PRODUCT SPECIFICATION FOR IMPERIUM 2 CIRCUIT CONNECTOR HARNESS TO DEVICE	SHEET No. 4 of 15
DOCUMENT NUMBER: PS-171467-001	CREATED / REVISED BY: J.Quiles	CHECKED BY: M.Data	APPROVED BY: A. Patel

4.3 TEMPERATURE

Operating: -40°C to +125°C (including T-Rise from load)

Storage/Non-operating: -40°C to +85°C

4.6 CONNECTOR DURABILITY

100 Cycles mechanical / non environmental durability. See details in 5.5.2

REVISION: B	ECR/ECN INFORMATION: EC No: UCP2014-4994 DATE: 2013/09/23	TITLE: PRODUCT SPECIFICATION FOR IMPERIUM 2 CIRCUIT CONNECTOR HARNESS TO DEVICE	SHEET No. 5 of 15
DOCUMENT NUMBER: PS-171467-001	CREATED / REVISED BY: J.Quiles	CHECKED BY: M.Data	APPROVED BY: A. Patel

5.0 PERFORMANCE

5.1 T-RISE:

5.1.1 Temperature Rise vs. Current for 1/0 cable size

Imperium - Temperature Rise Profile

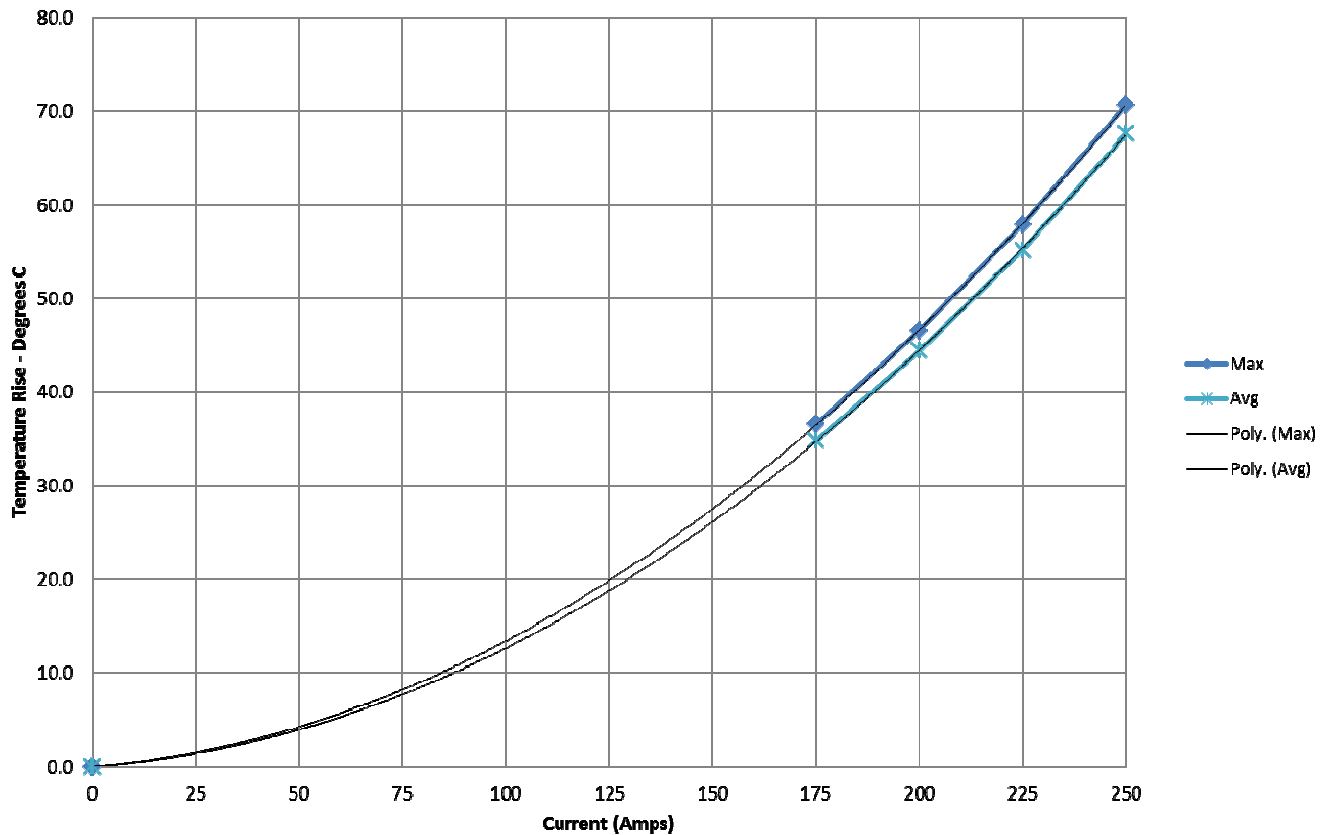

REVISION: B	ECR/ECN INFORMATION: EC No: UCP2014-4994 DATE: 2013/09/23	TITLE: PRODUCT SPECIFICATION FOR IMPERIUM 2 CIRCUIT CONNECTOR HARNESS TO DEVICE	SHEET No. 6 of 15
DOCUMENT NUMBER: PS-171467-001	CREATED / REVISED BY: J.Quiles	CHECKED BY: M.Data	APPROVED BY: A. Patel

5.1.2 Voltage Drop vs. Current for 1/0 cable size

Imperium - Voltage Drop Profile

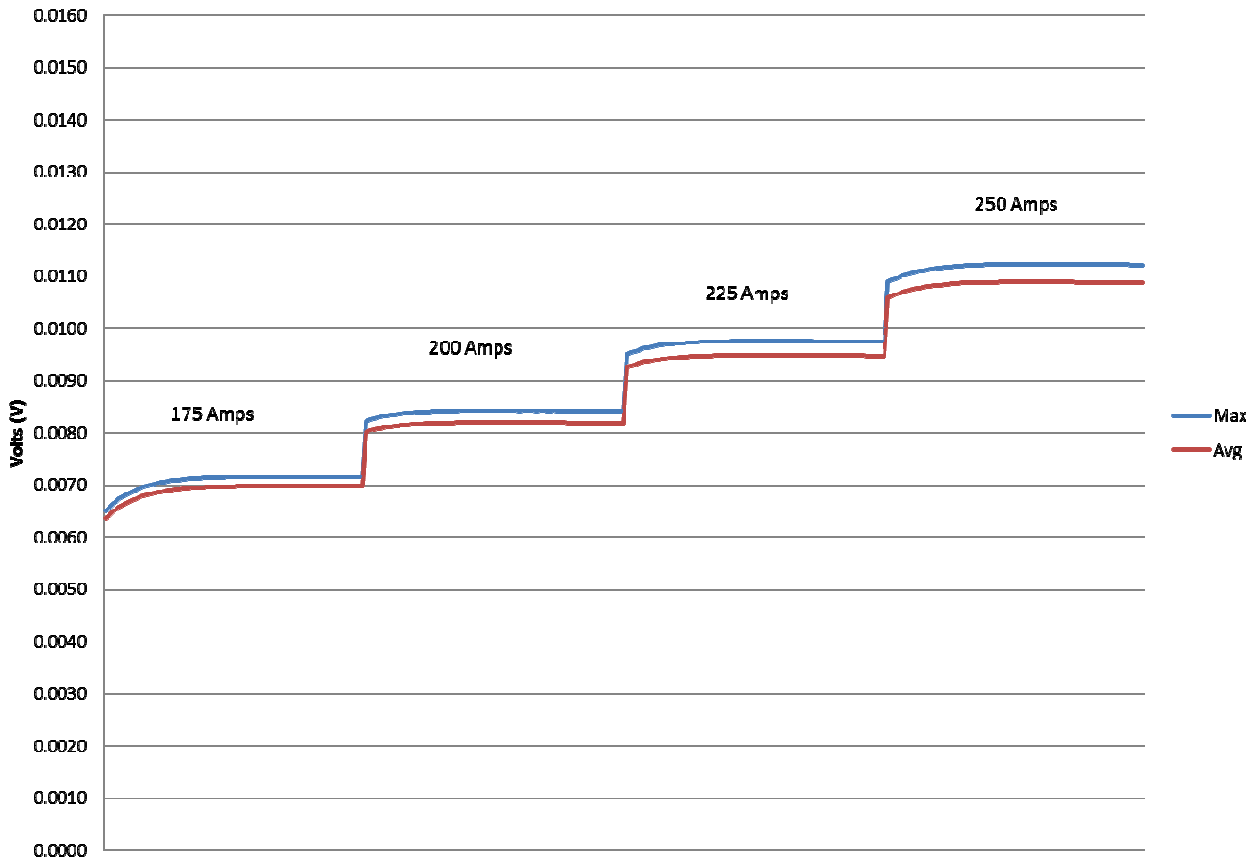

REVISION: B	ECR/ECN INFORMATION: EC No: UCP2014-4994 DATE: 2013/09/23	TITLE: PRODUCT SPECIFICATION FOR IMPERIUM 2 CIRCUIT CONNECTOR HARNESS TO DEVICE	SHEET No. 7 of 15
DOCUMENT NUMBER: PS-171467-001	CREATED / REVISED BY: J.Quiles	CHECKED BY: M.Data	APPROVED BY: A. Patel

5.2 ELECTRICAL PERFORMANCE

DESCRIPTION	TEST CONDITION	REQUIREMENT	RESULT
INITIAL CIRCUIT RESISTANCE (LOW LEVEL) See figure 1	Mate connectors; apply maximum voltage of 20 mV and current of 100 mA	Initial: Power Circuit: 1.0 mΩ max Shield Circuit: 10 mΩ max HVIL Circuit: 10 mΩ max	Power Circuit: 0.50 mΩ Shield Circuit: 8.0 mΩ HVIL Circuit: 6.0 mΩ
VOLTAGE DROP @ RATED CURRENT	Mate connectors; apply maximum current of 250 amps	Voltage drop: Power Circuit 20 mV	See Chart; Section 5.1.2

DESCRIPTION	TEST CONDITION	REQUIREMENT	RESULT
INSULATION RESISTANCE	Apply 500 VDC between adjacent terminals or ground	5,000 MΩ minimum	Pass
DIELECTRIC WITHSTANDING VOLTAGE	Apply 3000 VDC for 1 minute between: <ul style="list-style-type: none"> • power to power • power to shield • power to HVIL 	No break down	Pass

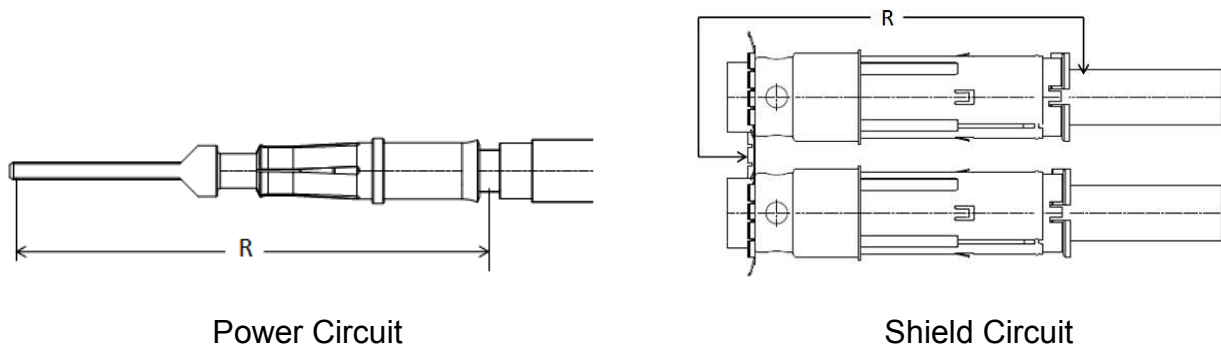

FIGURE 1

REVISION: B	ECR/ECN INFORMATION: EC No: UCP2014-4994 DATE: 2013/09/23	TITLE: PRODUCT SPECIFICATION FOR IMPERIUM 2 CIRCUIT CONNECTOR HARNESS TO DEVICE	SHEET No. 8 of 15
DOCUMENT NUMBER: PS-171467-001	CREATED / REVISED BY: J.Quiles	CHECKED BY: M.Data	APPROVED BY: A. Patel

5.3 ENVIRONMENTAL PERFORMANCE WITH 1/0 CABLE PER 2.2.3

DESCRIPTION	TEST CONDITION	REQUIREMENT	RESULT Δ CHANGE IN mΩ FROM INITIAL
MECHANICAL SHOCK AND VIBRATION	<p>Mated connectors Shock and Vibrate</p> <p>Shock: 35G half-sine shock pulse using 10 positive pulses per axis with a 5-10 millisecond duration for the pulse</p> <p>Vibration: Random vibrate for 8 hours in each of the 3 axes</p>	<p>USCAR2 5.4.6</p> <p>Power Circuit: 1.50 mΩ max change Shield Circuit : 20 mΩ HVIL Circuit: 10 mΩ max change</p>	<p>Power Circuit: Avg: 0.10 Max: 0.25</p> <p>Shield Circuit: Avg: 1.0 Max: 10.0</p> <p>HVIL Circuit: Avg: 0.25 Max: 2.0</p> <p>No Discontinuities observed</p> <p>Passes USCAR2 body vibration requirements</p>
THERMAL SHOCK	Mate connectors, expose to 100 cycles from -40°C to 125°C	<p>Power Circuit: 0.12 mΩ max change Shield Circuit: 50.0 mΩ max change HVIL Circuit: 10.0 mΩ max change</p>	<p>Maximum Change: Power Circuit: no change Shield Circuit: TBD HVIL Circuit: no change</p>
TEMPERATURE LIFE	Mate Connectors, expose to 1008 hours at 125°C	<p>Power Circuit: 0.12mΩ max change Shield Circuit: 50.0 mΩ max change HVIL Circuit: 10.0 mΩ max change</p>	<p>Maximum Change: Power Circuit: 0.25 mΩ Shield Circuit: 45.0 mΩ HVIL Circuit: 2.0 mΩ</p>
CYCLIC TEMPERATURE AND HUMIDITY	Mate connectors: expose to 10 cycles from -40°C/ 80% RH to 125°C/ 80% RH	<p>Power Circuit: 0.12 mΩ max change Shield Circuit: 50.0 mΩ max change HVIL Circuit: 10.0 mΩ max change</p>	<p>Maximum Change: Power Circuit: 0.25 mΩ Shield Circuit: 45.0 mΩ HVIL Circuit: 2.0 mΩ</p>

REVISION: B	ECR/ECN INFORMATION: EC No: UCP2014-4994 DATE: 2013/09/23	TITLE: PRODUCT SPECIFICATION FOR IMPERIUM 2 CIRCUIT CONNECTOR HARNESS TO DEVICE	SHEET No. 9 of 15
DOCUMENT NUMBER: PS-171467-001	CREATED / REVISED BY: J.Quiles	CHECKED BY: M.Data	APPROVED BY: A. Patel

5.4 SEAL PERFORMANCE:

5.4.1 FLUID RESISTANT (immerse one sample in each fluid listed in table below for 30 minutes then leave wet for 7 days)

Test	Sample / Fluid	Temperature	Visual Exam	Initial I/R @ 500VDC			Post I/R @ 500VDC			Visual Exam	Notes
				wire-wire	wire-shield	MX150 wire-wire	wire-wire	wire-shield	MX150 wire-wire		
Fluid Resistance (USCAR-2)	1 - Gasoline	23°C ± 5°C	ok	>2GΩ	>2GΩ	>2GΩ	>2GΩ	>2GΩ	>2GΩ	ok	
	2 - Diesel Fuel	23°C ± 5°C	ok	>2GΩ	>2GΩ	>2GΩ	>2GΩ	>2GΩ	>2GΩ	ok (*see note)	Some seal swelling observed which did not affect sample performance during testing.
	3 - Engine Oil	50°C ± 5°C	ok	>2GΩ	>2GΩ	>2GΩ	>2GΩ	>2GΩ	>2GΩ	ok	
	4 - Ethanol	23°C ± 5°C	ok	>2GΩ	>2GΩ	>2GΩ	>2GΩ	>2GΩ	>2GΩ	ok	
	5 - Power Steering Fluid	50°C ± 5°C	ok	>2GΩ	>2GΩ	>2GΩ	>2GΩ	>2GΩ	>2GΩ	ok	
	6 - Automatic Transmission Fluid	50°C ± 5°C	ok	>2GΩ	>2GΩ	>2GΩ	>2GΩ	>2GΩ	>2GΩ	ok	
	7 - Engine Coolant	50°C ± 5°C	ok	>2GΩ	>2GΩ	>2GΩ	>2GΩ	>2GΩ	>2GΩ	ok	
	8 - Brake Fluid	50°C ± 5°C	ok	>2GΩ	>2GΩ	>2GΩ	>2GΩ	>2GΩ	>2GΩ	ok	

5.4.2 HIGH PRESSURE SPRAY; PRESSURE/VACUUM; DUST; SUBMERSION

DESCRIPTION	TEST CONDITION	REQUIREMENT	RESULT
High Pressure Spray	Mated ISO 16750 - IP6K9K USCAR2 5.8.1 Heat soak samples at max ambient temperature (150 °C) for 2 hours. Run 4 cycles of 2 hr heat soak and 30 min submersion in 15 grams per liter room temp salt water at depth of 30-40 cm, measuring for Isolation Resistance each cycle	No evidence of physical damage/ No trace of fluid ingress	PASS

REVISION: B	ECR/ECN INFORMATION: EC No: UCP2014-4994 DATE: 2013/09/23	TITLE: PRODUCT SPECIFICATION FOR IMPERIUM 2 CIRCUIT CONNECTOR HARNES TO DEVICE	SHEET No. 10 of 15
DOCUMENT NUMBER: PS-171467-001	CREATED / REVISED BY: J.Quiles	CHECKED BY: M.Data	APPROVED BY: A. Patel

Pressure /Vacuum	Mated Submerge samples in salt water solution of 15-16 grams of table salt per liter of water at room temperature. Bend cables 90° and add air pressure slowly to 48KPa for 15 seconds switch from pressure to vacuum to 48KPa for 15 seconds	No trace of fluid ingress during vacuum or loss of sealing under pressure	PASS
Dust	Mated Subject sample to a 2.0 kg/m3 concentration of Talcum Powder measuring <75µ for a period of 24 hours	No trace of dust ingress - IP6	PASS
Submersion	Mated 2 hr heat soak, 30 minute submersion (1-8 @ 125°C) (9 & 10 @ 85°C)	No trace of fluid ingress	PASS

5.5 MECHANICAL PERFORMANCE:

5.5.1 FREE HANGING LOAD TEST

DESCRIPTION	TEST CONDITION	REQUIREMENT	RESULT
AXIAL HANG	Mated and mounted to panel 200 N weight straight in-line pull for 1 minute	No evidence of physical damage	PASS
90° HANG	Mated and mounted to panel 200 N weight 90° pull loading in four directions for 1 minute	No evidence of physical damage	PASS
45° HANG	Mated and mounted to panel 200 N weight 45° pull loading in four directions for 1 minute	No evidence of physical damage	PASS

REVISION: B	ECR/ECN INFORMATION: EC No: UCP2014-4994 DATE: 2013/09/23	TITLE: PRODUCT SPECIFICATION FOR IMPERIUM 2 CIRCUIT CONNECTOR HARNESS TO DEVICE	SHEET No. 11 of 15
DOCUMENT NUMBER: PS-171467-001	CREATED / REVISED BY: J.Quiles	CHECKED BY: M.Data	APPROVED BY: A. Patel

5.5.2 MISC MECHANICAL:

DESCRIPTION	TEST CONDITION	REQUIREMENT	RESULT
MATING FORCE, 2 CIRCUIT CONNECTOR	Mate connectors at a rate of 25 ± 6 mm per minute	----	144 N max 116 N avg
UNMATING FORCE, 2 CIRCUIT CONNECTOR (latches disengaged)	Unmate connectors at a rate of 25 ± 6 mm per minute	----	190 N max 130 N avg
DURABILITY W/O ENVIRONMENT	Mate connectors 100 cycles at a maximum rate of 10 cycles per minute	----	No damage which would impair operation
POWER TERMINAL TO PIN MATE/UNMATE FORCE	Mate and unmate receptacle power terminal to male power pin 10 times	----	@ 1X Mate: 46 N max Unmate: 40 N max @ 10X Mate: 41 N max Unmate: 26 N max
POWER TERMINAL INSERTION INTO HOUSING	Axial insertion force of the terminal into the housing at a rate of 25 ± 6 mm per minute	----	36 N max 26 N avg
CONTACT RETENTION Terminal extraction force from housing (latch retention force with TPA)	Axial pullout force on the terminal in the housing at a rate of 25 ± 6 mm per minute	----	Power Terminal: 542 N min HVIL Terminal: 28 N min
HVIL SEAL CAP WELD STRENGTH	Pull welded cap for header and receptacle housing	----	80 N min

REVISION: B	ECR/ECN INFORMATION: EC No: UCP2014-4994 DATE: 2013/09/23	TITLE: PRODUCT SPECIFICATION FOR IMPERIUM 2 CIRCUIT CONNECTOR HARNES TO DEVICE	SHEET No. 12 of 15
DOCUMENT NUMBER: PS-171467-001	CREATED / REVISED BY: J.Quiles	CHECKED BY: M.Data	APPROVED BY: A. Patel

HARNESS TO HEADER POLARIZATION EFFECTIVENESS	Unmated to mated <ul style="list-style-type: none"> Apply insertion force up to 200 N Visual check of polarization 	Cannot be mated	PASS
HARNESS TO HEADER KEYING EFFECTIVENESS	Unmated to mated <ul style="list-style-type: none"> Apply insertion force up to 200 N Visual check of keying 	Cannot be mated	PASS
UNPROTECTED DROP TEST HARNESS ASSY	Drop samples 3 times on 6 sides onto concrete floor from 1 meter	No evidence of physical damage	PASS
CABLE CRIMPED TO TERMINAL PULL FORCE	Crimped 1/0 (aught) cable to terminal	----	2975 N min 3355 N avg
CABLE SEAL CAP EXTRACTION FORCE	Apply axial force at a rate of 25 mm per min until removed	----	145 N min
CONNECTOR LATCH RETENTION	Mated harness to header axial pull force	----	137 N min 150 N avg

REVISION: B	ECR/ECN INFORMATION: EC No: UCP2014-4994 DATE: 2013/09/23	TITLE: PRODUCT SPECIFICATION FOR IMPERIUM 2 CIRCUIT CONNECTOR HARNESS TO DEVICE	SHEET No. 13 of 15
DOCUMENT NUMBER: PS-171467-001	CREATED / REVISED BY: J.Quiles	CHECKED BY: M.Data	APPROVED BY: A. Patel

5.5 ENVIRONMENTAL SEQUENCE

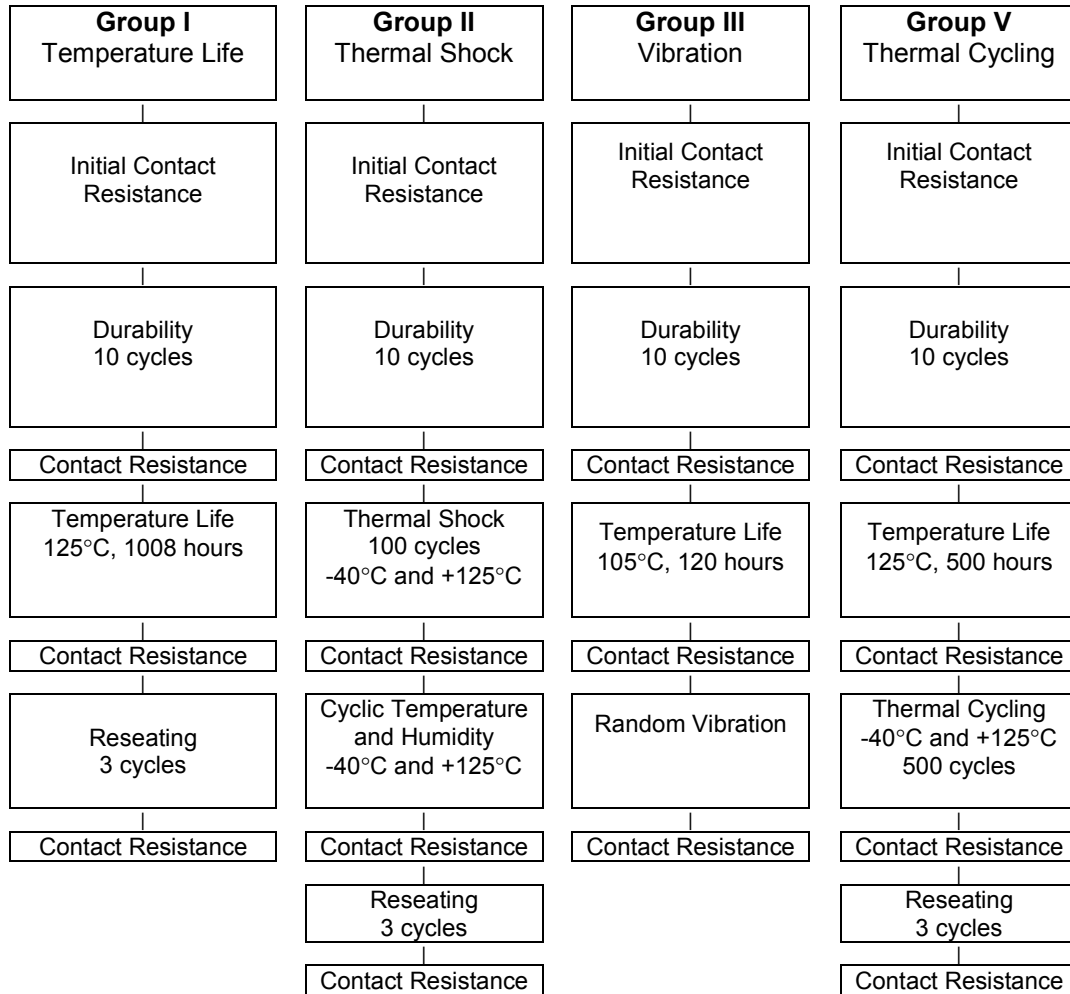

REVISION: B	ECR/ECN INFORMATION: EC No: UCP2014-4994 DATE: 2013/09/23	TITLE: PRODUCT SPECIFICATION FOR IMPERIUM 2 CIRCUIT CONNECTOR HARNESS TO DEVICE	SHEET No. 14 of 15
DOCUMENT NUMBER: PS-171467-001	CREATED / REVISED BY: J.Quiles	CHECKED BY: M.Data	APPROVED BY: A. Patel

This page intentionally left blank

REVISION: B	ECR/ECN INFORMATION: EC No: UCP2014-4994 DATE: 2013/09/23	TITLE: PRODUCT SPECIFICATION FOR IMPERIUM 2 CIRCUIT CONNECTOR HARNES TO DEVICE	SHEET No. 15 of 15
DOCUMENT NUMBER: PS-171467-001	CREATED / REVISED BY: J.Quiles	CHECKED BY: M.Data	APPROVED BY: A. Patel